

Gaggenau

en User manual and installation instructions

BMP224, BMP225

Microwave Oven

Table of contents

INFORMATION FOR USE

1	Safety	2
2	Preventing material damage	5
3	Environmental protection and saving energy	6
4	Familiarising yourself with your appliance	7
5	Accessories	9
6	Before using for the first time	9
7	Basic operation	10
8	Microwave	10
9	Grill	11
10	MicroCombi	12
11	Sequential operation	12
12	Automatic programmes	13
13	Individual recipes	15
14	Timer functions	17
15	Childproof lock	17
16	Basic settings	18
17	Cleaning aid	19
18	Cleaning and servicing	19
19	Troubleshooting	21
20	Disposal	22
21	Customer Service	22
22	How it works	23
23	INSTALLATION INSTRUCTIONS	29
23.1	Safe installation	29

1 Safety

Observe the following safety instructions.

1.1 General information

- Read this instruction manual carefully.
- Keep the instruction manual and the product information safe for future reference or for the next owner.
- Do not connect the appliance if it has been damaged in transit.

1.2 Intended use

Only a licensed professional may connect appliances without plugs. Damage caused by incorrect connection is not covered under the warranty.

The appliance can only be used safely if it is correctly installed according to the safety instructions. The installer is responsible for ensuring that the appliance works perfectly at its installation location.

Only use this appliance:

- To prepare meals and drinks.
- Under supervision. Never leave the appliance unattended when cooking for short periods.
- For household use and similar applications, such as: In kitchens for employees in shops, offices and other commercial sectors; in agriculture; by customers in hotels and other residential facilities; in bed and breakfasts.
- up to an altitude of max. 4000 m above sea level.

This appliance complies with the standards EN 55011 and CISPR 11. It is a group 2, class B product. Group 2 means that microwaves are produced for the purpose of heating food. Class B means that the appliance is suitable for private households.

1.3 Restriction on user group

This appliance may be used by children aged 8 or over and by people who have reduced physical, sensory or mental abilities or inadequate experience and/or knowledge, provided that they are supervised or have been instructed on how to use the appliance safely and have understood the resulting dangers.

Do not let children play with the appliance.

Children must not perform cleaning or user maintenance unless they are at least 15 years old and are being supervised.

Keep children under the age of 8 years away from the appliance and power cable.

1.4 Safe use

Always place accessories in the cooking compartment the right way round.

→ "Accessories", Page 9

⚠ WARNING – Risk of fire!

Combustible objects that are left in the cooking compartment may catch fire.

- ▶ Never store combustible objects in the cooking compartment.
- ▶ If smoke is emitted, the appliance must be switched off or the plug must be pulled out and the door must be held closed in order to stifle any flames.

Loose food remnants, fat and meat juices may catch fire.

- ▶ Before using the appliance, remove the worst of the food residues and remnants from the cooking compartment, heating elements and accessories.

⚠ WARNING – Risk of burns!

The appliance and its parts that can be touched become hot during use.

- ▶ Caution should be exercised here in order to avoid touching heating elements.
- ▶ Young children under 8 years of age must be kept away from the appliance.

Accessories and cookware get very hot.

- ▶ Always use oven gloves to remove accessories or cookware from the cooking compartment.

When the cooking compartment is hot, any alcoholic vapours inside may catch fire. The appliance door may spring open. Hot steam and jets of flame may escape.

- ▶ Only use small quantities of drinks with a high alcohol content in food.
- ▶ Do not heat spirits ($\geq 15\%$ vol.) when undiluted (e.g. for marinating or pouring over food).
- ▶ Open the appliance door carefully.

⚠ WARNING – Risk of scalding!

The accessible parts of the appliance become hot during operation.

- ▶ Never touch these hot parts.
- ▶ Keep children at a safe distance.

Hot steam may escape when you open the appliance door. Steam may not be visible, depending on the temperature.

- ▶ Open the appliance door carefully.
- ▶ Keep children at a safe distance.

If there is water in the cooking compartment when it is hot, this may create hot steam.

- ▶ Never pour water into the cooking compartment when the cooking compartment is hot.

⚠ WARNING – Risk of injury!

Scratched glass in the appliance door may develop into a crack.

- ▶ Do not use any harsh or abrasive cleaners or sharp metal scrapers to clean the glass on the appliance door, as they may scratch the surface.

The hinges on the appliance door move when the door is opened and closed, which could trap your fingers.

- ▶ Keep your hands away from the hinges.

⚠ WARNING – Risk of electric shock!

Incorrect repairs are dangerous.

- ▶ Repairs to the appliance should only be carried out by trained specialist staff.
- ▶ Only use genuine spare parts when repairing the appliance.
- ▶ If the power cord of this appliance is damaged, it must be replaced by the manufacturer, the manufacturer's Customer Service or a similarly qualified person in order to prevent any risk.

If the insulation of the power cord is damaged, this is dangerous.

- ▶ Never let the power cord come into contact with hot appliance parts or heat sources.
- ▶ Never let the power cord come into contact with sharp points or edges.
- ▶ Never kink, crush or modify the power cord.

An ingress of moisture can cause an electric shock.

- ▶ Do not use steam- or high-pressure cleaners to clean the appliance.

If the appliance or the power cord is damaged, this is dangerous.

- ▶ Never operate a damaged appliance.
- ▶ Never operate an appliance with a cracked or fractured surface.
- ▶ Never pull on the power cord to unplug the appliance. Always unplug the appliance at the mains.
- ▶ If the appliance or the power cord is damaged, immediately unplug the power cord or switch off the fuse in the fuse box.

▶ Call customer services. → Page 22

⚠ WARNING – Risk of suffocation!

Children may put packaging material over their heads or wrap themselves up in it and suffocate.

- ▶ Keep packaging material away from children.
- ▶ Do not let children play with packaging material.

Children may breathe in or swallow small parts, causing them to suffocate.

- ▶ Keep small parts away from children.
- ▶ Do not let children play with small parts.

1.5 Microwave

CAREFULLY READ THE IMPORTANT SAFETY INSTRUCTIONS AND KEEP THEM SAFE FOR FUTURE USE

⚠ WARNING – Risk of fire!

Using the appliance for anything other than its intended purpose is dangerous and may cause damage. For example, heated slippers and pillows filled with grain or cereal may catch fire, even several hours later.

- ▶ Never dry food or clothing with the appliance.
- ▶ Never heat up slippers, pillows filled with grain or cereal, sponges, damp cleaning cloths or similar with the appliance.
- ▶ The appliance must only be used to prepare food and drink.

Food and its packaging and containers may catch fire.

- ▶ Never heat food in heat-retaining packaging.
- ▶ Do not leave food unattended while it is heating in containers made of plastic, paper or other combustible materials.
- ▶ Never set the microwave power too high or the cooking time too long. Follow the instructions provided in this user manual.
- ▶ Never use the microwave to dry food.
- ▶ Never defrost or heat food with a low water content, such as bread, at too high a microwave power or for too long.

Cooking oil may catch fire.

- ▶ Never use the microwave to heat cooking oil on its own.

⚠ WARNING – Risk of explosion!

Liquids and other food may easily explode when in containers that have been tightly sealed.

- ▶ Never heat liquids or other food in containers that have been tightly sealed.

⚠ WARNING – Risk of burns!

Foods with peel or skin may burst or explode during heating, or even afterwards.

- ▶ Never cook eggs in their shell or heat hard-boiled eggs in their shell.
- ▶ Never cook shellfish or crustaceans.
- ▶ Always prick the yolk of eggs before microwaving.
- ▶ The skin of foods that have a peel or skin, such as apples, tomatoes, potatoes and sausages, may burst. Before heating, prick the peel or skin.

Heat is not distributed evenly through baby food.

- ▶ Never heat baby food in closed containers.
- ▶ Always remove the lid or teat.
- ▶ Stir or shake well after heating.
- ▶ Check the temperature before giving the food or drink to a child.

Heated food gives off heat. The cookware may become hot.

- ▶ Always use oven gloves to remove cookware or accessories from the cooking compartment.

Airtight packaging may burst when food is heated.

- ▶ Always follow the instructions on the packaging.
- ▶ Always use oven gloves to remove the dishes from the cooking compartment.

The accessible parts of the appliance become hot during operation.

- ▶ Never touch these hot parts.
- ▶ Keep children at a safe distance.

Using the appliance for anything other than its intended purpose is dangerous. This is because, for instance, overheated slippers, pillows filled with grain or cereal, sponges and damp cleaning cloths, etc., may cause burns to the skin.

- ▶ Never dry food or clothing with the appliance.
- ▶ Never heat up slippers, pillows filled with grain or cereal, sponges, damp cleaning cloths or similar with the appliance.

- ▶ The appliance must only be used to prepare food and drink.

⚠ WARNING – Risk of scalding!

There is a possibility of delayed boiling when a liquid is heated. This means that the liquid reaches the boiling temperature without the usual steam bubbles rising to the surface. Exercise caution even when only gently shaking the container. The hot liquid may suddenly boil over and splatter.

- ▶ Always place a spoon in the container when heating liquids. This prevents delayed boiling.

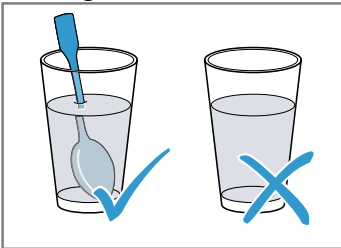

⚠ WARNING – Risk of injury!

Unsuitable cookware may crack. Porcelain or ceramic cookware can have small perforations in the handles and lid. These perforations conceal a cavity below. If moisture penetrates this cavity, it could cause the cookware to crack.

- ▶ Only use microwave-safe cookware. Cookware and containers made from metal or cookware with metal edging may lead to sparks being formed during simple microwave operation. The appliance is damaged.

- ▶ Never use metal containers during microwave-only operation.
- ▶ Only use microwave-safe cookware or use the microwave in combination with a type of heating.

⚠ WARNING – Risk of electric shock!

The appliance uses a high voltage.

- ▶ Never remove the casing.

⚠ WARNING – Risk of serious harm to health!

Inadequate cleaning may destroy the surface of the appliance, reduce its service life, and lead to dangerous situations, such as escaping microwave energy.

- ▶ Clean the appliance on a regular basis, and remove any food residue immediately.
- ▶ Always keep the cooking compartment, door seal, door and door stop clean.
→ "Cleaning and servicing", Page 19

Never operate the appliance if the cooking compartment door or the door seal is damaged. Microwave energy may escape.

- ▶ Never use the appliance if the cooking compartment door, the door seal or the plastic door frame is damaged.
- ▶ Any repair work must only be carried out by customer service.

Microwave energy will escape from appliances that do not have any casing.

- ▶ Never remove the casing.
- ▶ Contact our after-sales service if maintenance or repair work is needed.

2 Preventing material damage

2.1 General

ATTENTION!

Alcoholic vapours may catch fire in the hot cooking compartment and cause permanent damage to the appliance. The appliance door may spring open due to an explosion and it may fall off. The door panels may shatter and fragment. Due to the resulting negative pressure, the cooking compartment may become considerably deformed inwards.

- ▶ Do not heat spirits ($\geq 15\%$ vol.) when undiluted (e.g. for marinating or pouring over food).

When the cooking compartment is hot, any water inside it will create steam. The change in temperature may cause damage.

- ▶ Never pour water into the cooking compartment when it is still hot.

The prolonged presence of moisture in the cooking compartment leads to corrosion.

- ▶ Always wipe away the condensation after cooking. Always allow the cooking compartment to cool down with the door closed after cooking at high temperatures.
- ▶ Do not keep moist food in the cooking compartment for a long time with the door closed.
- ▶ Do not store food in the cooking compartment.
- ▶ Take care not to trap anything in the appliance door.

If the seal is very dirty, the appliance door will no longer close properly during operation. This may damage the front of adjacent kitchen units.

- ▶ Keep the seal clean at all times.
- ▶ Never operate the appliance if the seal is damaged or missing.

Sitting or placing objects on the appliance door may damage it.

- ▶ Do not place, hang or support objects on the appliance door.

2.2 Microwave

Follow these instructions when using the microwave.

ATTENTION!

Metal touching the wall of the cooking compartment will cause sparks, which may damage the appliance or the inner door pane.

- ▶ Metal (e.g. a spoon in a glass) must be kept at least 2 cm from the cooking compartment walls and the inside of the door.

Placing aluminium containers in the appliance may cause sparks, which will damage the appliance.

- ▶ Do not use aluminium containers in the appliance.

Operating the appliance without food in the cooking compartment may lead to overloading.

- ▶ Do not switch on the microwave unless there is food inside. The only exception to this rule is when performing a short cookware test.

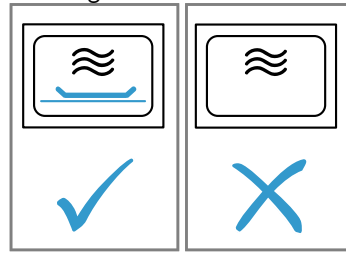

If you prepare several bags of microwave popcorn in immediate succession at a microwave power level that is too high, the cooking compartment may be damaged.

- ▶ Leave the appliance to cool down for several minutes between each use.
- ▶ Never set a microwave power level that is too high.
- ▶ Use a maximum microwave output of 600 watts.
- ▶ Always place the popcorn bag on a glass plate.

Using unsuitable cookware may result in damage.

- ▶ When using the grill or the microwave combined operation, only use cookware that can withstand high temperatures.

3 Environmental protection and saving energy

3.1 Disposing of packaging

The packaging materials are environmentally compatible and can be recycled.

- ▶ Sort the individual components by type and dispose of them separately.

3.2 Saving energy

If you follow these instructions, your appliance will use less power.

Open the appliance door as little as possible during operation.

- This will maintain the temperature in the cooking compartment and eliminate the need for the appliance to reheat.

Hide the clock in standby mode.

- The appliance saves energy in standby mode.

Note:

The appliance requires:

- A maximum of 1 W in standby mode with the display switched on
- A maximum of 0.5 W in standby mode with the display switched off

4 Familiarising yourself with your appliance

4.1 Control panel

You can use the control panel to configure all functions of your appliance and to obtain information about the operating status.

Note: On certain models, specific details such as colour and shape may differ from those pictured.

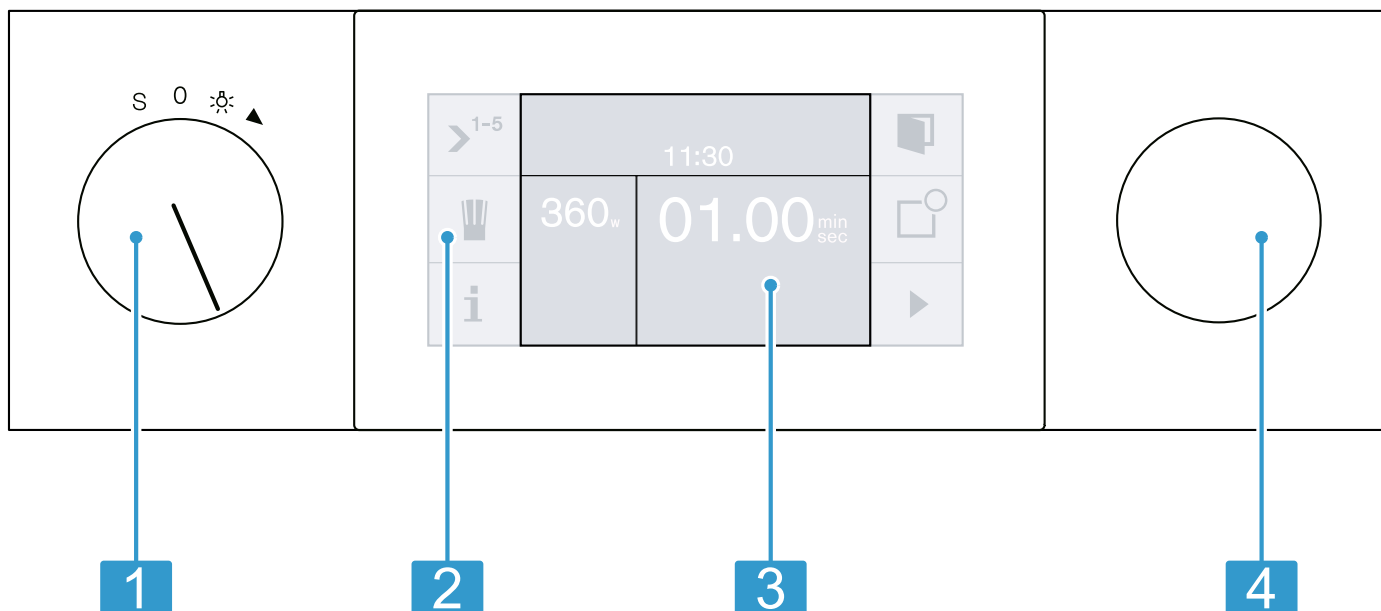

1	Function selector	Use the function selector to set the microwave output setting, type of heating and other functions.
2	Touch fields	You can use the touch fields to set various functions directly.
3	Display	The display shows the current setting values and selection options.
4	Rotary selector	Use the rotary selector to change the settings in the different operating modes.

Positions of the function selector

Use the function selector to select the functions or types of heating.

Position	Function
0	Zero setting
☼	Light
2	900 W microwave
3	600 W microwave
4	360 W microwave
5	180 W microwave
6	90 W microwave
7	Grill
S	Basic settings

Symbols

Use the symbols to start or stop functions, or to navigate in the menu.

Symbol	Function
▶	Start
■	Stop
	Pause or end
X	Cancel
C	Delete
✓	Confirm or save settings
>	Selection arrow
🚪	Open the appliance door
i	Call up additional information
💬	Calling up additional tips
🍽️	Calling up the automatic programmes Calling up individual recipes

Symbol	Function
	Saving
	Edit settings
	Childproof lock
	Call up the timer menu
	Sequential operation
	Record menu
	Enter a name
	Delete letters
	Microwave, letting the dish rest
	Demo mode
	Short-term timer
	Stopwatch

Automatic programs

	Weight
	Defrosting
	Cooking and combi cooking

Combination mode

	Calling up the grill
	Removing the grill
	Adding the grill
	Calling up the microwave
	Removing the microwave
	Adding the microwave

Colours and display

The different colours guide the user in the relevant setting situations.

Colours

Orange	<ul style="list-style-type: none"> ■ Initial settings ■ Main functions
Blue	Basic settings
White	Adjustable values

Display

The symbols, values and displays change, depending on the situation.

Zoom	Values and symbols that have just been selected are displayed in a larger font.
Reduced display	After a short time, the information shown on the display is reduced and only the most important information remains. You can change this preset function in the basic settings. → Page 18

4.2 Automatic door opening

If you press , the appliance door springs open. Use the recessed grip on the side of the appliance to open the appliance door fully.

Note: If the childproof lock is activated or in the event of a power cut, the automatic door opening function does not work. Use the recessed grip on the side of the appliance to open the appliance door manually.

4.3 Additional Information

Press **i** to call up additional information.

Before starting, you receive information, e.g. about the type of heating. You can therefore check whether the current setting is suitable for the dish.

During operation, you receive information, e.g. about the time that has elapsed and the time remaining.

4.4 Cooking compartment

The functions in the cooking compartment make your appliance easier to use.

Interior lighting

When you open the appliance door, the lighting in the cooking compartment switches on. If the appliance door remains open, the light switches off again after a short time.

When the operation starts, the interior lighting switches on.

Cooling fan

The cooling fan switches on and off as required. The hot air escapes through the ventilation slots above the appliance door.

ATTENTION!

Covering the ventilation slots will cause the appliance to overheat.

- ▶ Do not cover the ventilation slots.

To cool the cooking compartment more quickly after operation, the cooling fan continues to run for a certain period afterwards. If the appliance is running in microwave operation, the appliance remains cool, but the cooling fan still switches on. The cooling fan may continue to run even when microwave operation has ended.

Condensation

Condensation can occur in the cooking compartment and on the appliance door when cooking. Condensation is normal and does not adversely affect appliance operation. Wipe away the condensation after cooking.

4.5 Standby

The appliance switches to standby mode if you have not set any function or activated the childproof lock. In standby mode, the brightness of the control panel is reduced.

Different things can be displayed in standby mode. The GAGGENAU logo and the time are preset.

The brightness of the display depends on the vertical viewing angle. You can change the display and the brightness at any time in the basic settings.

→ "Basic settings", Page 18

4.6 Safety shut-off



For your safety, your appliance has a safety shut-off function. If you do not operate your appliance for 12 hours, your appliance switches every kind of heating off and the display shows a message.

This excludes programming using a long-term timer. If you turn the function selector to 0, you are now able to start the appliance again as usual.

5 Accessories

Use original accessories. These have been made especially for your appliance.

The accessories supplied may differ depending on the appliance model.

Accessories		Use
Wire rack		<ul style="list-style-type: none"> Wire rack for grilling and browning Wire rack as a place for the cookware
Glass tray		<p>Splash guard when grilling directly on the wire rack</p> <p>When grilling, place the wire rack into the glass tray.</p> <p>Tip: You can use the glass tray as cookware during microwave operation.</p>
Rod		<ul style="list-style-type: none"> Heating liquids in narrow containers Preventing delayed boiling When heating liquids, always place the rod or a spoon into the container

6 Before using for the first time

Configure the settings for initial start-up. Clean the appliance and accessories.

6.1 Initial start-up

When the appliance is connected to the power supply for the first time or following a lengthy power cut, the settings for the initial start-up of your appliance appear.

Note: You can change → Page 18 these settings at any time in the basic settings.

Setting the language

The display shows the preset language.

- Use the rotary selector to set the required display language.
- Press ✓ to confirm.

Note: When you change the language, the system restarts. This process takes a few seconds.

Setting the time format

The display shows the two possible formats 24h and AM/PM. The 24h time format is preselected.

- Use the rotary selector to set the required time format.
- Press ✓ to confirm.

Setting the time

The display shows the time.

- Use the rotary selector to set the required time.
- Press ✓ to confirm.

Setting the date format

The display shows the 3 possible date formats D.M.Y, D/M/Y and M/D/Y. The date format D.M.Y. is preselected.

- Use the rotary selector to set the required date format.
- Press ✓ to confirm.

Setting the date

The display shows the preset date. The day setting is active.

- Use the rotary selector to set the required day.
- Use > to switch to the month setting
- Use the rotary selector to set the month.

4. Use > to switch to the year setting
5. Use the rotary selector to set the year.
6. Press ✓ to confirm.

Ending the initial start-up

The display shows "Initial set-up complete".

- ▶ Press ✓ to confirm.
- ✓ The appliance enters standby mode and the standby screen appears. The appliance is ready to use.

6.2 Cleaning the appliance before using it for the first time

Clean the cooking compartment and accessories before using the appliance to prepare food for the first time.

1. Ensure that there is no leftover packaging, accessories or other objects in the cooking compartment.

2. Clean the smooth surfaces in the cooking compartment with a soft, damp cloth.
3. Close the appliance door.
4. Ventilate the room while the appliance is heating.
5. Heat up the appliance for 30 minutes at level 3 using the Grill mode. → *Page 11*
6. Allow the appliance to cool down.
7. Once the cooking compartment has cooled down, clean the smooth surfaces with soapy water and a dish cloth.

6.3 Cleaning the accessories

- ▶ Clean the accessory thoroughly with soapy water and a soft dish cloth.

7 Basic operation

7.1 Activating the appliance

1. To exit standby mode, open or close the door, turn the function selector or touch a control panel.
2. Set the required function.

Notes

- When "Standby screen" = "Off" is selected in the basic settings, turn the function selector to exit standby mode.
- If you do not make any settings for an extended period after activation, the standby display is shown.
- When the door is open, the interior lighting switches off after a short time.

7.2 Interrupting the operation

1. To interrupt the operation, press II.
2. Press ▶ to resume operation.

7.3 Cancelling the operation

- ▶ To stop the operation and delete the settings, turn the function selector to 0.

Note: The fan can also continue to run when the door is open. This is normal.

8 Microwave

You can use the microwave to cook, heat up, bake or defrost food very quickly. The microwave can be used on its own or in combination with a type of heating.

8.1 Microwave-safe cookware and accessories

To heat food evenly and avoid damaging your appliance, it is important to use the right cookware and accessories.

Note: Read the manufacturer's instructions before using any cookware in the microwave. If in doubt, carry out a cookware test.

Microwave-safe

Cookware and accessories	Reason
Cookware made from heat-resistant, microwave-safe material: <ul style="list-style-type: none">■ Glass■ Glass ceramic■ Porcelain■ Temperature-resistant plastic■ Fully glazed ceramic without cracks	These materials allow microwaves to pass through. Microwaves do not damage heat-resistant cookware.
Metal cutlery	Note: You can use metal cutlery, e.g. place a spoon in a glass, to prevent delayed boiling.

ATTENTION!

Metal touching the wall of the cooking compartment will cause sparks, which may damage the appliance or the inner door pane.

- ▶ Metal (e.g. a spoon in a glass) must be kept at least 2 cm from the cooking compartment walls and the inside of the door.

Not microwave-safe

Cookware and accessories	Reason
Metal cookware	Metal does not allow microwaves to pass through. The food hardly heats up.
Cookware with gold or silver decoration	Microwaves can damage gold and silver decoration. Tip: You can only use this kind of cookware if the manufacturer guarantees that it is microwave-safe.

8.2 Microwave power settings

This is where you can find an overview of the different microwave output settings and when to use them.

Microwave output in watts	Use
90	Defrost delicate foods.
180	Defrost food and continue cooking.
360	Cook meat and fish or heat delicate foods.
600	Heat and cook food.
900	Heat liquids.

9 Grill

You can brown or gratinate your food using the grill. You can use the grill on its own or in combination with the microwave.

9.1 Grill settings

Your appliance has multiple grill settings.

Grill setting	Use
1 (low)	<ul style="list-style-type: none"> ▪ Soufflés ▪ Deep-dish bakes
2 (medium)	<ul style="list-style-type: none"> ▪ Shallow bakes ▪ Fish
3 (high)	<ul style="list-style-type: none"> ▪ Steaks ▪ Sausages ▪ Toast

9.2 Setting Grill mode

- Use the function selector to set the full surface grill.
 - ✓ The display shows and grill setting 3.
- Use the rotary selector to set the grill setting.

Notes

- You can set the microwave output settings for a specific duration:
 - 900 W for 30 minutes
 - 90 W, 180 W, 360 W and 600 W for 90 minutes
- The maximum setting is for heating liquids. To protect the appliance, it reduces the maximum microwave output setting after some time. Full power is made available again after a cooling period.

8.3 Setting the microwave

- Use the function selector to set the required microwave output setting.
- Use the rotary selector to set the cooking time.
- Press to start.
 - ✓ The appliance starts. You can see the cooking time counting down.
 - ✓ A signal tone sounds once the time has elapsed. If you press , open the appliance door or set the function selector to 0, you can end the signal early. The operation has finished.

Note: If you open the appliance door during cooking, the microwave operation stops. To continue the operation, close the appliance door and press .

Tips

- You can change the duration at any time using the rotary selector.
- You can change the output at any time using the function selector. To start, press .
- You can call up the elapsed cooking time by pressing . If you press , you return to the standard display.

- If required, set the cooking time and move the cooking time end to a later time:
 - Press to call up the sequential operation.
 - Use to select and set the "Cooking time" function.
 - Use to select and set the "Cooking time end" function.
- Press to start.

Tips

- You can use the rotary selector to change the grill setting at any time.
- You can use the function selector to change the operation mode at any time. To start, press .

Interrupting the operation

- To interrupt the operation, press .
- Press to resume operation.

Cancelling the operation

- ▶ To stop the operation and delete the settings, turn the function selector to 0.

Note: The fan can also continue to run when the door is open. This is normal.

10 MicroCombi





To reduce the cooking time and brown your meals, you can use the grill in combination with the microwave.

Notes

- You can switch on all microwave output settings except for 600 W and 900 W.
- You can also combine the MicroCombi with the sequential operation for the microwave.





10.1 Setting MicroCombi

Note: You can start combined operation with the grill or microwave output setting. This example starts with the Grill mode.







1. Use the function selector to set Grill mode.
2. Use the rotary selector to set the grill setting.
- ✓  for microwave appears in the right-hand control panel.
3. Use  to add a microwave output setting.
4. Use the function selector to set the required microwave output setting.
5. Use the rotary selector to set the cooking time.
6. Press  to start.
- ✓ The appliance starts. You can see the cooking time counting down.
- ✓ A signal tone sounds once the time has elapsed. If you press , open the appliance door or set the function selector to 0, you can end the signal early. The operation has finished.

Changing settings



You can change the the grill setting or the microwave output setting and the duration.

1. To change the settings during the operation and stop the operation, press .
2. Use  to focus on the grill mode or  to focus on the microwave mode.
3. Use the function selector to change the microwave output setting.
4. Use the rotary selector to change the grill setting or the duration of the microwave output setting.
5. Press  to start.

Deleting settings

1. To delete the settings during the operation and stop the operation, press .
2. Use  to focus on the grill mode or  to focus on the microwave mode.
3. Use  to delete the grill mode or  to delete the microwave mode.
4. Press  to start.

Interrupting the operation

1. To interrupt the operation, press .
2. Press  to resume operation.

Cancelling the operation





- ▶ To stop the operation and delete the settings, turn the function selector to 0.



Note: The fan can also continue to run when the door is open. This is normal.

11 Sequential operation

With a sequential operation, you can set up to 5 different types of heating and cooking times that are set one after another.

11.1 Setting a sequential operation

1. Use the function selector to set the required microwave output setting or the grill.
2. Press .¹⁻⁵
- ✓ The sequential operation menu is displayed.
3. Use the rotary selector to set the cooking time or grill setting.
4. Use  to select the second phase.
5. **Note:** You can set a compensation time between 2 microwave output settings so that the temperature can be evenly distributed in the food. To set the compensation time, press 0_w and use the rotary selector to set a duration.
Use the function selector to set the required microwave output setting or the grill.
6. Use the rotary selector to set the cooking time or grill setting.
7. Use  to select the third phase.
8. Use the function selector to set the required microwave output setting or the grill.
9. Use the rotary selector to set the cooking time or grill setting.
10. Use  to select "Cooking time" .

11. Use the rotary selector to set the required cooking time.
12. Press  to confirm.
- ✓ The main menu for the sequential operation is displayed. The settings for the phases are shown on the display bar.
13. Press  to start.
- ✓ The appliance starts. You can see the cooking time counting down.
- ✓ Once the cooking time has elapsed, the appliance switches off. A signal tone sounds. If you press , open the appliance door or set the function selector to 0, you can end the signal early. The operation has finished.

Notes

- You can add the combined operation to the sequential operation.
- You can only select the 900 W microwave output setting once.
- You cannot combine the grill with the 600 W and 900 W microwave output setting.
- The order of each setting is entirely up to you. You can start with the duration, the microwave output setting or the grill.
- If you open the appliance door during cooking, the fan may continue to run.

Changing sequential operation

1. Press **II**.
 - ✓ The operation stops.
2. Use the rotary selector to set the cooking time, temperature or grill setting.
3. Press **>**¹⁻⁵ and change the settings.
4. Use **✓** to exit the menu.
5. Press **▶** to start.

Deleting settings

- ▶ Press **X**.

Interrupting the operation

1. To interrupt the operation, press **II**.
2. Press **▶** to resume operation.

Cancelling the operation

- ▶ To stop the operation and delete the settings, turn the function selector to **0**.

Note: The fan can also continue to run when the door is open. This is normal.

11.2 Cooking time end

In grill mode, you can delay the cooking time end to a later time. This function is not available in combination with the microwave.

Enter the cooking time and delay the cooking time end until 15:30, for example. The electronics system calculates the start time. The appliance starts automatically at 14:50 and switches off at 15:30, for example.

Do not leave food which spoils easily in the oven for too long.

Delaying the cooking time end

Requirement: The grill, grill setting and cooking time are set.

1. Use **>** to select "Cooking time end" **⌚**.

2. Use the rotary selector to set the required cooking time end.
3. Press **✓** to confirm.
 - ✓ The display shows a notification that a cooking time end has been set.
4. Press **✓** to confirm.
5. Press **▶** to start.
 - ✓ The appliance switches to standby. The display shows the operating mode, the grill setting, the cooking time and the remaining time until the start.
 - ✓ The appliance starts at the calculated time and automatically switches off once the cooking time has elapsed.
 - ✓ Once the cooking time has elapsed, the appliance switches off. A signal tone sounds. If you press **✓**, open the appliance door or set the function selector to **0**, you can end the signal early. The operation has finished.

Changing the cooking time

1. Press **II**.
2. Use **>** to select "Cooking time" **⌚**.
3. Use the rotary selector to set the required cooking time.
4. Press **✓** to confirm.
5. Press **▶** to start.

Changing the cooking time end

1. Press **II**.
2. Use **>** to select "Cooking time end" **⌚**.
3. Use the rotary selector to set the required cooking time end.
4. Press **✓** to confirm.
5. Press **▶** to start.

Deleting settings

- ▶ Press **X**.

Cancelling the entire procedure

- ▶ Turn the function selector to **0**.

12 Automatic programmes

The automatic programs help you prepare different dishes and automatically select the optimal settings.

12.1 Information on Automatic programmes

Follow these tips to achieve optimal cooking results:

- Only use food that is in perfect condition.
- Take the food out of its packaging and weigh it. If you cannot set the exact weight on the appliance, round the weight up or down.
- Only use microwave-safe, heat-resistant cookware, e.g. made of glass or ceramic.
- Place the food in the cold cooking compartment.
- It is not possible to set weights outside the weight range.
- With many dishes, a signal tone sounds after a certain time. Turn or stir the food.

Defrosting

- Freeze and store food flat and in portion-sized quantities at -18 °C.
- Place the frozen food on flat cookware, such as a glass or porcelain plate.

- Food may not be completely defrosted by the end of the programme. The food can nonetheless be further processed.
- The defrosted food should be left to stand for an additional 15 to 90 minutes until it reaches an even temperature.
- Liquid is produced when defrosting meat or poultry. When turning, drain off any liquid. Do not reuse the liquid for other purposes or allow it to come into contact with other foods.
- Bread and bread rolls become hard quickly. Defrost only in the required amounts.
- Place frozen bread rolls in the oven. Only pre-baked bread rolls are suitable.
- After turning, remove any minced meat that has already defrosted.
- Whole poultry should be placed on the cookware breast-side down and poultry portions skin-side down.

Vegetables

- Fresh vegetables: Cut into pieces of equal size. Add one tablespoon of water per 100 g.

- Frozen vegetables: Only suitable for blanched, not pre-cooked vegetables. It is not suitable for frozen vegetables in cream sauce. Add 1 to 3 tablespoons of water. Do not add any water for spinach or red cabbage.

Potatoes

- Boiled potatoes: Cut into pieces of an equal size. Add two tablespoons of water and some salt per 100 g.
- Unpeeled boiled potatoes: Use potatoes of the same thickness. Wash them and prick the skin. Place the wet potatoes in a dish. Do not add water.
- Baked potatoes: Use potatoes of the same thickness. Wash, dry and prick the skin.

Rice

- Do not use brown rice or boil-in-the-bag rice.
- Add two to two-and-a-half times the amount of water to the rice.

Poultry

- Only use chicken portions at refrigerator temperature.
- Prick the skin here and there with a fork.
- Place chicken portions in the cookware skin-side up.

12.2 Resting time

Some dishes require a resting time in the cooking compartment after the programme has ended.

Dish	Resting time
Vegetables	Approx. 5 minutes
Potatoes	Approx. 5 minutes First pour off the remaining water.
Rice	Approx. 5-10 minutes

12.3 Setting a programme

1. Set the function selector to any operating mode. The function selector must not be moved to  or S.







12.4 Programme table

You can cook food very easily using the programmes. You select a programme and enter the weight of your food. The programme applies the most suitable settings.



Defrosting

Dish	Suitable food	Weight range in kg	Cookware or accessories, shelf height
Bread and cake ¹	Bread, whole, round or long; sliced bread; sponge cake, yeast cake, fruit flan, cakes without icing, cream or gelatine	0.20 – 1.50	Shallow cookware without lid Cooking compartment floor

¹ Observe the signals given when it is time to turn the food.

2. Press  to display the automatic programs.
3. Press  to confirm.
 - ✓ The display shows the first programme.
4. Use the rotary selector to select the desired programme.
5. Use  to select the  function.
6. Turn the rotary selector to set the weight.
7. Press  to confirm.
8. Press  to start.
 - ✓ The appliance starts. You can see the cooking time counting down.
 - ✓ A signal tone sounds once the time has elapsed. If you press , open the appliance door or set the function selector to 0, you can end the signal early. The operation has finished.

Displaying tips

1. To display tips on the cookware, accessories or the shelf positions, press .
2. Press  to exit the display.

Displaying notifications

i[®] appears for important information and indicates that an action is required.

1. Press **i** to display notifications for the preparation.
2. Press  to exit the display.

Notes

- For some dishes, the display provides instructions for turning or stirring during preparation. Follow the information provided. If you do not turn or stir the dish, the programme runs as normal until it reaches the end.
- Opening the appliance door pauses the operation. After closing the appliance door, continue the operation by pressing .

Interrupting the operation

1. To interrupt the operation, press **II**.
2. Press  to resume operation.

Cancelling the operation

- ▶ To stop the operation and delete the settings, turn the function selector to 0.

Note: The fan can also continue to run when the door is open. This is normal.

Dish	Suitable food	Weight range in kg	Cookware or accessories, shelf height
Meat and poultry ¹	Joints, flat pieces of meat, minced meat, chicken, poulard, duck	0.20 – 2.00	Shallow cookware without lid Cooking compartment floor
Fish ¹	Whole fish, fish fillet and fish steak	0.10 – 1.00	Shallow cookware without lid Cooking compartment floor

¹ Observe the signals given when it is time to turn the food.

Cooking

Dish	Suitable food	Weight range in kg	Cookware or accessories, shelf height
Fresh vegetables ¹	Cauliflower, broccoli, carrots, kohlrabi, leeks, peppers, courgettes	0.15 – 1.00	Covered cookware Cooking compartment floor
Frozen vegetables ¹	Cauliflower, broccoli, carrots, kohlrabi, red cabbage, spinach	0.15 – 1.00	Covered cookware Cooking compartment floor
Boiled potatoes ¹	Boiled potatoes, unpeeled boiled potatoes, chopped potatoes of the same size	0.20 – 1.00	Covered cookware Cooking compartment floor
Rice ¹	Rice, long-grain rice	0.05 – 0.30	Deep cookware with lid Cooking compartment floor
Baked potatoes	Waxy potatoes, predominantly waxy potatoes or floury potatoes, approx. 6 cm thick	0.20 – 1.50	Wire rack Cooking compartment floor

¹ Observe the signals given when it is time to stir the food.

Combi cooking

Dish	Suitable food	Weight range in kg	Cookware or accessories, shelf height
Frozen lasagne	Lasagne bolognese	0.30 – 1.00	Uncovered cookware Cooking compartment floor
Fresh chicken portions	Chicken thigh, half chicken	0.50 – 1.80	Glass tray and wire rack Cooking compartment floor

13 Individual recipes

You can save, record or programme up to 50 individual recipes. You can name your recipes so that you can access them quickly and easily when needed.

13.1 Recording a recipe

You can set up to 5 phases one after the other and record these.

- Use the function selector to set the required microwave output setting or the grill.
 - ✓ The display shows **W**.
- Press **W** and use the rotary selector to select "Individual recipes".
- Press **✓** to confirm.
- Use the rotary selector to select a free memory location.
- Press **rec**.
- Use the rotary selector to set the cooking time or grill setting.

- Press **▶** to start.
 - ✓ The appliance records the first phase and you can see the cooking time counting down. You can record an additional phase once the cooking time has elapsed. To end the phase early, press **■**.
- If required, select one of the options:
 - To save the recipe, press **↵** and enter a name under ABC.
→ "Entering a name", Page 16
 - To cancel the recipe without saving, press **X**.
 - To continue the recording, carry out the following steps.
- Press **rec** to continue the recording.
- Use the function selector to set the required microwave output setting or the grill.
- Use the rotary selector to set the cooking time or grill setting.
- Press **▶** to start.
 - ✓ When grilling, the appliance records the cooking time.

13. Press ■ to end this phase.
 - ✓ The appliance saves this phase with the cooking time.
14. If required, select one of the options:
 - To save the recipe, press ↵ and enter a name under ABC.
→ "Entering a name", Page 16
 - To cancel the recipe without saving, press ✕.
 - To continue the recording, repeat the previous steps.

Notes

- When you open the appliance door, the recording of the phase ends.
- You can operate the appliance in combined operation.
→ "MicroCombi", Page 12

13.2 Programming a recipe

You can programme and save up to 5 phases for the preparation.

1. Use the function selector to set the required microwave output setting or the grill.
 - ✓ The display shows ▮.
2. Press ▮ and use the rotary selector to select "Individual recipes".
3. Press ✓ to confirm.
4. Use the rotary selector to select a free memory location.
5. Press ↵.
6. Enter a name under "ABC". → Page 16
7. Press ↵.
8. Use ▶ to select the first phase.
 - ✓ The appliance displays the type of heating. You can use the function selector to change the type of heating. Operation in combined operation is possible.
→ Page 12
9. Use the rotary selector to set the cooking time or grill setting.
10. Select one of the following options:
 - Press ▶ to select the next phase.
 - Finish making entries once the preparation is complete.
11. Select one of the following options:
 - Press ✓ to save.
 - To cancel without saving, press ✕.

13.3 Entering a name

1. Enter a name for the recipe under "ABC".
2. Use the rotary selector to select the letters.
A new word always begins with a capital letter.
Latin characters, certain special characters and numbers are available.
3. Briefly press ▶^Ä to position the cursor to the right.
4. Press and hold ▶^Ä to switch to umlauts and special characters.
5. Press ▶^Ä twice to insert a break.

6. Briefly press ▶^Ä to position the cursor to the right.
7. Press and hold ▶^Ä to switch to normal characters.
8. Press ▶^Ä twice to insert a break.
9. Press ✕ to delete a letter.
10. Select one of the following options:
 - Press ✓ to save.
 - To cancel without saving, press ✕.

13.4 Starting a recipe

1. Use the function selector to select any type of heating.
 - ✓ The display shows ▮.
2. Press ▮ and use the rotary selector to select "Individual recipes".
3. Press ✓ to confirm.
4. Use the rotary selector to select the desired recipe.
5. Press ▶ to start.
 - ✓ The operation starts and you can see the cooking time counting down.
 - ✓ The display shows the settings for the phases on the display bar.

Note: You can use the rotary selector to change the grill setting for the grill, and to change the duration for the microwave output setting while the recipe is cooking. This does not change the saved recipe.

13.5 Changing a recipe

You can change the settings of a recorded or programmed recipe.

1. Use the function selector to select any type of heating.
 - ✓ The display shows ▮.
2. Press ▮ and use the rotary selector to select "Individual recipes".
3. Press ✓ to confirm.
4. Use the rotary selector to select the desired recipe.
5. Press ↵.
6. Use ▶ to select the required phase.
 - ✓ The display shows the settings. You can use the rotary selector or function selector to change the settings.
7. Select one of the following options:
 - Press ✓ to save.
 - To cancel without saving, press ✕.

13.6 Deleting a recipe

1. Use the function selector to select any type of heating.
 - ✓ The display shows ▮.
2. Press ▮ and use the rotary selector to select "Individual recipes".
3. Press ✓ to confirm.
4. Use the rotary selector to select the desired recipe.
5. Use C to delete the recipe.
6. Press ✓ to confirm.

14 Timer functions

Your appliance has different timer functions, with which you can control its operation.

14.1 Calling up the timer menu

Requirements

- The appliance is activated.
- The function selector is set to 0 or ⚙️.
- ▶ Press ⏸.
- ✓ The timer menu is displayed.

Notes

- If you turn the function selector to a type of heating or basic settings S while the short-term timer or stop watch is running, a notification appears on the display. Press ✓ to confirm the notification and interrupt the short-term timer or the stop watch. The appliance is ready to use.
- In order to continue the short-term timer or stop watch, turn the function selector to 0 or ⚙️.
- You can use the short-term timer and the stopwatch at the same time.
- If the function selector is set to 0, the display only shows the short-term timer.
- If the function selector is set to ⚙️, the display shows the short-term timer and the stopwatch.

14.2 Short-term timer

The short-term timer only runs if you have not set any other function. You can enter a maximum of 90 minutes.

Set the short-term timer

1. Call up the timer menu.
 - ✓ The display shows "Timer" ⌚.
2. Use the rotary selector to set the required cooking time.
3. Press ▶ to start.
 - ✓ The appliance closes the timer menu and the time counts down.
 - ✓ The display shows ⌚ and the time that has elapsed.
 - ✓ A signal tone sounds once the time has elapsed. If you press ✓, you can end the signal early.

Tip: Press ✕ to exit the timer menu. The settings are lost.

Stopping the short-term timer

1. Press ⏸.
2. Use ▶ and "Timer" to select ⌚ and press II.
3. To allow the timer to continue counting down, press ▶.

Switching off the timer early

1. Press ⏸.
2. Use ▶ and "Timer" to select ⌚ and press C.

14.3 Stopwatch

The stopwatch only runs if you have not set any other function. The stopwatch counts upwards from 0 seconds up to 90 minutes. You can use the pause function to pause the stopwatch occasionally.

Starting the stopwatch

1. Press ⏸.
2. Use ▶ to select "Stopwatch" ⌚.
3. Press ▶ to start.
 - ✓ The appliance closes the timer menu and the time counts down.
 - ✓ The display shows ⌚ and the time that has elapsed.

Stopping the stopwatch

1. Press ⏸.
2. Use ▶ to select "Stopwatch" ⌚.
3. Press II.
 - ✓ The time stops and the symbol switches to start ▶.
4. Press ▶ to start the stopwatch.
 - ✓ The time continues to run. Once it has reached 90 minutes, the display pulses and a signal tone sounds. If you press ✓, you can end the signal.
 - ✓ ⌚ goes out on the display and the procedure is ended.

Switching off the stopwatch

1. Press ⏸.
2. Use ▶ to select "Stopwatch" ⌚.
3. Press C.

15 Childproof lock

You can secure your appliance to prevent children from accidentally switching it on or changing the settings.

15.1 Activating the childproof lock

Requirements

- The childproof lock is set to "Available" in the basic settings.
- The function selector is set to 0.

- ▶ Press and hold 🔒 for approx. 6 seconds.
- ✓ The standby display appears and the display shows 🔒.

Note: If there is a power cut after the childproof lock has been activated, the childproof lock may be deactivated when the power comes back on.

15.2 Deactivating the childproof lock

Requirement: The function selector is set to 0.











- ▶ Press and hold 🔒 for approx. 6 seconds.

16 Basic settings







You can configure the basic settings for your appliance to meet your needs.

16.1 Overview of the basic settings

Here you can find an overview of the basic settings and factory settings. The basic settings depend on the features of your appliance.

Symbol	Basic setting	Settings	Explanation
	Brightness	<ul style="list-style-type: none"> ■ 1 ■ 2 ■ 3 ■ 4 ■ 5¹ ■ 6 ■ 7 ■ 8 	Set the display brightness.
	Standby screen	<ul style="list-style-type: none"> ■ On¹ <ul style="list-style-type: none"> – Clock – Clock + GAGGENAU logo – Date – Date + GAGGENAU logo – Clock + date – Clock + date + GAGGENAU logo ■ Off 	<p>Set the appearance of the standby screen.</p> <p>Off: You can use this setting to reduce the standby energy consumption of your appliance.</p> <p>On: You can set multiple displays. Use ✓ to confirm "On" and use the rotary selector to set the required display.</p>
	Display	<ul style="list-style-type: none"> ■ Reduced¹ ■ Standard 	Reduced: After a short time, the display shows only the most important information.
	Touch field colour	<ul style="list-style-type: none"> ■ Grey¹ ■ White 	Set the colour of the symbols on the touch fields.
	Touch field tone type	<ul style="list-style-type: none"> ■ Tone 1¹ ■ Tone 2 ■ Off 	Set the signal tone when you touch a touch field.
	Touch field tone volume	<ul style="list-style-type: none"> ■ 1 ■ 2 ■ 3 ■ 4 ■ 5¹ ■ 6 ■ 7 ■ 8 	Set the volume of the touch field tone.
	Signal volume	<ul style="list-style-type: none"> ■ 1 ■ 2 ■ 3 ■ 4 ■ 5¹ ■ 6 ■ 7 ■ 8 	Set the volume of the signal tone.
	Time format	<ul style="list-style-type: none"> ■ AM/PM ■ 24 h¹ 	Set the display of the time in the 12-hour or 24-hour format.
	Time	Current time	Set the time.
	Clock change	<ul style="list-style-type: none"> ■ Manual¹ ■ Automatic 	Automatic: The clock automatically adjusts to daylight saving time. For normal time and daylight savings time, set when you want the time to be converted.

¹ Factory setting (may vary according to model)

Symbol	Basic setting	Settings	Explanation
	Date format	<ul style="list-style-type: none"> ■ D.M.Y¹ ■ D/M/Y ■ M/D/Y 	Set the date format.
	Date	Current date	Set the current date. Press ➤ to switch between the year, month and day.
	Language	See selection on the appliance	Set the language for the text display. Note: When you change the language, the system restarts. This process takes a few seconds. The basic settings are then closed.
	Factory settings	Resetting the appliance to factory settings	Notes <ul style="list-style-type: none"> ■ Individual recipes are also deleted if the appliance is reset to factory settings. ■ After restoring factory settings, the "Initial settings" menu is displayed. To reset the appliance to the factory settings, use ✓ to confirm. Press ✕ to cancel.
	Demo mode	<ul style="list-style-type: none"> ■ On ■ Off¹ 	The demo mode is used for demonstration purposes only. The appliance does not heat up in demo mode but all other functions are available. Activate "Off" for normal mode. The setting is only possible in the first 3 minutes after connecting the appliance.
	Childproof lock	<ul style="list-style-type: none"> ■ Not available¹ ■ Available 	Available: The childproof lock is available. → "Childproof lock", Page 17

¹ Factory setting (may vary according to model)

16.2 Changing the basic settings

1. Turn the function selector to S.
2. Use the rotary selector to select the required basic setting.
3. Press **_**.
4. Use the rotary selector to set the basic setting.
5. Use **✓** to save or use **✕** to cancel.
✓ The current initial setting is exited.
6. Turn the function selector to **0** to exit the basic settings menu.

17 Cleaning aid

17.1 Setting the cleaning aid

1. Add a few drops of washing-up liquid to a cup of water.
2. Place a spoon in the cup to prevent delayed boiling.
3. Place the cup in the centre of the cooking compartment.
4. Set the 600 W microwave output setting.
5. Set the cooking time to 5 minutes.
6. Start the operation.
7. Once the duration has elapsed, keep the door closed for a further 3 minutes.
8. Wipe out the cooking compartment with a soft cloth.
9. Leave the cooking compartment to dry with the door open.

18 Cleaning and servicing

To keep your appliance working efficiently for a long time, it is important to clean and maintain it carefully.

18.1 Cleaning products

Only use suitable cleaning agents.

WARNING – Risk of electric shock!

An ingress of moisture can cause an electric shock.

- ▶ Do not use steam- or high-pressure cleaners to clean the appliance.

ATTENTION!

Unsuitable cleaning agents damage the surfaces of the appliance.

- ▶ Do not use harsh or abrasive cleaning products.
- ▶ Do not use cleaning products with a high alcohol content.
- ▶ Do not use hard scouring pads or cleaning sponges.
- ▶ Do not use any special cleaners for cleaning the appliance while it is hot.

- ▶ Only use glass cleaners, glass scrapers or stainless steel care products if recommended in the cleaning instructions for the relevant part.

Salt contained in new sponge cloths may damage surfaces.

- ▶ Wash new sponge cloths thoroughly before use.

You can find out which cleaning products are suitable for each surface or part of the appliance in the individual cleaning instructions.

18.2 Cleaning the appliance

Clean the appliance as specified. This will ensure that the different parts and surfaces of the appliance are not damaged by incorrect cleaning or unsuitable cleaning products.

⚠ WARNING – Risk of burns!

The appliance and its parts that can be touched become hot during use.

- ▶ Caution should be exercised here in order to avoid touching heating elements.
- ▶ Young children under 8 years of age must be kept away from the appliance.

⚠ WARNING – Risk of fire!

Loose food remnants, fat and meat juices may catch fire.

- ▶ Before using the appliance, remove the worst of the food residues and remnants from the cooking compartment, heating elements and accessories.

⚠ WARNING – Risk of injury!

Scratched glass in the appliance door may develop into a crack.

- ▶ Do not use any harsh or abrasive cleaners or sharp metal scrapers to clean the glass on the appliance door, as they may scratch the surface.

1. Read the information on cleaning products.
→ Page 19
2. Observe the information on cleaning the appliance components or surfaces.
3. Unless otherwise specified:
 - Clean the components of the appliance with hot soapy water and a dish cloth.
 - Dry with a soft cloth.

18.3 Cleaning the front of the appliance

ATTENTION!

Incorrect cleaning may damage the front of the appliance.

- ▶ Do not use glass cleaner, metal scrapers or glass scrapers for cleaning.
- ▶ To prevent corrosion on stainless steel fronts, remove any limescale, grease, starch and albumin (e.g. egg white) stains immediately.
- ▶ On stainless steel surfaces, use special stainless steel cleaning products suitable for hot surfaces.

1. Read the information on cleaning products.
→ Page 19
2. Clean the front of the appliance using hot soapy water and a dish cloth.

Note: Slight differences in colour on the front of the appliance are caused by the use of different materials, such as glass, plastic and metal.

3. For stainless steel appliance fronts, apply a thin layer of the stainless steel cleaning product with a soft cloth.

You can obtain the stainless steel cleaning products from the after-sales service or the online shop.

4. Dry with a soft cloth.

18.4 Cleaning aluminium

1. Clean using a mild window-cleaning product.
2. Using a window cloth or a non-fluffing microfibre cloth, wipe over the surfaces lightly in a horizontal direction.

18.5 Cleaning the cooking compartment

ATTENTION!

Incorrect cleaning may damage the cooking compartment.

- ▶ Do not use oven spray, abrasive materials or other aggressive oven cleaners.

Note:

In the event of extremely heavy soiling, use oven cleaner gel (order number 00311859 from customer service or from the online shop).

- Do not touch seals on the door or bulb
- Leave for no more than 12 hours
- Do not use it on hot surfaces
- Rinse off thoroughly with water
- Observe the manufacturer's instructions

1. Read the information on cleaning products.
→ Page 19
2. Clean with hot soapy water or a vinegar solution.
3. Use an oven cleaner that is suitable for stainless steel surfaces to remove very heavy soiling. Only use oven cleaner when the cooking compartment is cold.
Tip: To eliminate unpleasant odours, heat up a cup of water with a few drops of lemon juice for 1 to 2 minutes at maximum microwave output setting. Always place a spoon in the container to prevent delayed boiling.
4. Wipe out the cooking compartment with a soft cloth.
5. Leave the cooking compartment to dry with the door open.

18.6 Cleaning the control panel

ATTENTION!

Incorrect cleaning may damage the control panel.

- ▶ Never wipe the control panel with a wet cloth.

1. Read the information on cleaning products.
→ Page 19
2. Clean the control panel using a microfibre cloth or a soft, damp cloth.
3. Dry with a soft cloth.

18.7 Cleaning the door panels

ATTENTION!

Incorrect cleaning may damage the door panes.

- ▶ Do not use a glass scraper.

1. Read the information on cleaning products.
→ Page 19
2. Clean the door panels with a soft dish cloth and glass cleaner.
Note: Shadows on the door panels, which look like streaks, are caused by reflections made by the interior lighting.
3. Dry with a soft cloth.

18.8 Cleaning the door seal

Do not remove the door seal.

ATTENTION!

Incorrect cleaning may damage the door seal.

- ▶ Do not use metal scrapers or glass scrapers for cleaning.
- ▶ Do not use abrasive cleaning agents.

1. Read the information on cleaning products.
→ Page 19
2. Clean the door seal with hot soapy water and a soft dish cloth.
3. Dry with a soft cloth.

18.9 Cleaning the accessories

1. Read the information on cleaning products.
→ Page 19
2. Soften baked-on food remnants with a damp dish cloth and hot soapy water.
3. Clean the accessory with hot soapy water and a soft dish cloth or a scrubbing brush.
4. Clean the wire rack with stainless steel cleaner or in the dishwasher.
Use steel wool or oven cleaner to remove very heavy soiling.
5. Dry with a soft cloth.

19 Troubleshooting

You can rectify minor faults on your appliance yourself. Read the troubleshooting information before contacting after-sales service. This will avoid unnecessary costs.

WARNING – Risk of injury!

Improper repairs are dangerous.

- ▶ Repairs to the appliance should only be carried out by trained specialist staff.
- ▶ If the appliance is defective, call Customer Service.
→ "Customer Service", Page 22



WARNING – Risk of electric shock!

Incorrect repairs are dangerous.

- ▶ Repairs to the appliance should only be carried out by trained specialist staff.
- ▶ Only use genuine spare parts when repairing the appliance.
- ▶ If the power cord of this appliance is damaged, it must be replaced by the manufacturer, the manufacturer's Customer Service or a similarly qualified person in order to prevent any risk.

19.1 Malfunctions

Fault	Cause and troubleshooting
The appliance is not working.	The mains plug of the power cord is not plugged in. ▶ Connect the appliance to the power supply.
	The circuit breaker in the fuse box has tripped. ▶ Check the circuit breaker in the fuse box.
	There has been a power cut. ▶ Check whether the lighting in your kitchen or other appliances are working.
	Malfunction 1. Switch off the fuse in the fuse box. 2. Switch the fuse on after approx. 10 seconds. 3. If the malfunction occurs again, call customer service.
Appliance does not start.	Appliance door not fully closed. ▶ Close appliance door.
Food takes longer than usual to heat up.	The microwave power setting is set too low. ▶ Set a higher microwave output setting. → "Microwave", Page 10
	A larger amount than usual has been placed in the appliance. ▶ Set a longer cooking time. You need double the time when you have double the amount.
The food is colder than usual.	▶ Turn or stir the food from time to time during cooking.

Fault	Cause and troubleshooting
Appliance is switched on but controls not responding;  appears on the display.	Childproof lock is activated. ▶ Deactivate the childproof lock. → "Deactivating the childproof lock", Page 17
The appliance is not heating and  appears on the display.	Demo mode is activated. ▶ Deactivate demo mode. → "Basic settings", Page 18
The interior lighting is not working.	The halogen bulb is defective. ▶ Call the after-sales service. → "Customer Service", Page 22

19.2 Information on display panel

Fault	Cause and troubleshooting
The display shows the error message "Exxx"	An error has occurred. 1. Switch the appliance off and on again. ✓ If the fault was a one-off, the message disappears. 2. If the message appears again, call the after-sales service. Please specify the exact error message when calling. → "Customer Service", Page 22

19.3 Power cut

Your appliance can bridge a power cut of a few seconds. The operation continues. If the power cut lasts longer and the appliance was operating, the display shows a message. The operation is interrupted. After the power cut, you can start up the

appliance as usual. To do so, turn the function selector to the zero position.
→ "Initial start-up", Page 9

20 Disposal

20.1 Disposing of old appliance

Valuable raw materials can be reused by recycling.

1. Unplug the appliance from the mains.
2. Cut through the power cord.
3. Dispose of the appliance in an environmentally friendly manner.
Information about current disposal methods are available from your specialist dealer or local authority.



This appliance is labelled in accordance with European Directive 2012/19/EU concerning used electrical and electronic appliances (waste electrical and electronic equipment - WEEE). The guideline determines the framework for the return and recycling of used appliances as applicable throughout the EU.

21 Customer Service

Detailed information on the warranty period and terms of warranty in your country is available from our after-sales service, your retailer or on our website.

If you contact Customer Service, you will require the product number (E-Nr.) and the production number (FD) of your appliance. The contact details for Customer Service can be found in the enclosed Customer Service directory or on our website.

21.1 Product number (E-Nr.) and production number (FD)

You can find the product number (E-Nr.) and the production number (FD) on the appliance's rating plate. You will see the rating plate with these numbers if you open the appliance door.

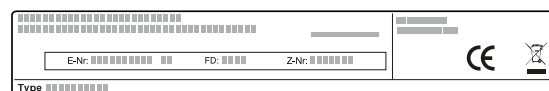

Make a note of your appliance's details and the Customer Service telephone number to find them again quickly.

22 How it works

Here, you can find the ideal settings for various dishes as well as the best accessories and cookware. We have tailored these recommendations to your appliance.

22.1 What is the best way to proceed?

In this section, you will find out the best way to proceed using step-by-step instructions to make optimal use of the recommended settings. You will get information on many meals, with details and tips on how to best use and set your appliance.

Tip

Cooking tips

- The recommended settings always apply to the cooking compartment when it is cold and empty.
- The times specified in the overviews are intended as a guide only. They will depend on the quality and composition of the food.

WARNING – Risk of scalding!

Hot liquid may spill over the sides of the accessory when it is removed from the cooking compartment.

- ▶ Remove hot accessories with care and always wear oven gloves.

1. Before using the appliance, remove all unnecessary cookware from the cooking compartment.
2. Select the desired food from the recommended settings.

Defrosting with the microwave

Note:

Cooking tips

- Freeze the food flat.
- Use microwave-safe cookware without a lid.
- Place the cookware on the bottom of the cooking compartment.
- Turn or stir the food 2 to 3 times during this time. When turning, remove any liquid that escapes during defrosting.
- Liquid is produced when defrosting meat or poultry. When turning, drain off any liquid. Do not continue to use this for other purposes or allow it to come into contact with other foods.
- After turning, remove any minced meat that has already defrosted.
- Separate any defrosted parts when turning.
- Delicate parts such as the legs and wings of chicken or fatty outer layers of roasts can be covered with small pieces of aluminium foil. The foil must not touch the walls of the appliance. Remove the foil half-way through the defrosting time.
- To allow the temperature to equalise, leave the defrosted food to rest for another 10 to 60 minutes in the appliance after switching it off. You can remove the giblets from poultry at this point.

Food	Weight	Microwave output setting	Duration
Whole pieces of meat, on the bone or boned	800 g	1. 180 W 2. 90 W	1. 15 mins ¹ 2. 15 – 25 mins
Whole pieces of meat, on the bone or boned	1000 g	1. 180 W 2. 90 W	1. 20 mins ¹ 2. 20 – 30 mins

¹ Turn the food several times.

² Separate any defrosted parts when turning.

³ Carefully stir the food occasionally.

⁴ Remove all packaging.

⁵ Only defrost cakes without icing, whipped cream, gelatine or custard.

⁶ Separate the pieces of cake.

3. Place the food in suitable cookware.
4. Place the cookware in the middle on the cooking compartment floor.
The food can then absorb the microwaves from all sides.
5. Use the recommended settings when configuring the appliance settings.
Set the shorter cooking time first. If necessary, increase the cooking time.
6. Use an oven cloth or oven gloves when taking hot cookware out of the cooking compartment.

22.2 Defrosting

With your appliance you can defrost frozen food.

Tips on defrosting, heating and cooking with the microwave

Follow these tips for good results when defrosting, heating and cooking with the microwave.

Issue	Tip
You want to prepare a different amount than that indicated in the table.	Increase or reduce the cooking times using the following rule of thumb: <ul style="list-style-type: none"> ■ Double the amount = almost double the cooking time ■ Half the amount = half the cooking time

Food	Weight	Microwave output setting	Duration
Whole pieces of meat, on the bone or boned	1500 g	1. 180 W 2. 90 W	1. 25 mins ¹ 2. 25 – 30 mins
Meat in pieces or slices	200 g	1. 180 W 2. 90 W	1. 5 – 8 mins ² 2. 5 – 10 mins
Meat in pieces or slices	500 g	1. 180 W 2. 90 W	1. 8 – 11 mins ² 2. 10 – 15 mins
Meat in pieces or slices	800 g	1. 180 W 2. 90 W	1. 10 mins ² 2. 10 – 15 mins
Minced meat, mixed	200 g	90 W	10 – 15 mins ¹
Minced meat, mixed	500 g	1. 180 W 2. 90 W	1. 5 mins ¹ 2. 10 – 15 mins
Minced meat, mixed	800 g	1. 180 W 2. 90 W	1. 10 mins ¹ 2. 15 – 20 mins
Poultry or poultry portions	600 g	1. 180 W 2. 90 W	1. 8 mins ¹ 2. 10 – 15 mins
Poultry or poultry portions	1200 g	1. 180 W 2. 90 W	1. 15 mins ¹ 2. 20 – 25 mins
Fish fillet, fish steak or fish slices	400 g	1. 180 W 2. 90 W	1. 5 mins ² 2. 10 – 15 mins
Whole fish	300 g	1. 180 W 2. 90 W	1. 3 mins ¹ 2. 10 – 15 mins
Whole fish	600 g	1. 180 W 2. 90 W	1. 8 mins ¹ 2. 15 – 20 mins
Vegetables, e.g. peas	300 g	180 W	10 – 15 mins ³
Fruit, e.g. raspberries	300 g	180 W	6 – 9 mins ³
Fruit, e.g. raspberries	500 g	1. 180 W 2. 90 W	1. 8 mins ³ 2. 5 – 10 mins
Butter, defrosting ⁴	125 g	1. 180 W 2. 90 W	1. 1 min 2. 1 – 2 mins
Butter, defrosting ⁴	250 g	1. 180 W 2. 90 W	1. 1 min 2. 2 – 4 mins
Loaf of bread	500 g	1. 180 W 2. 90 W	1. 8 mins ¹ 2. 5 – 10 mins
Loaf of bread	1000 g	1. 180 W 2. 90 W	1. 12 mins ¹ 2. 10 – 20 mins
Cakes, plain, e.g. sponge cake ^{5, 6}	500 g	90 W	10 – 15 mins
Cakes, plain, e.g. sponge cake ^{5, 6}	750 g	1. 180 W 2. 90 W	1. 5 mins 2. 10 – 15 mins
Cakes, moist, e.g. fruit flan, cheesecake ⁵	500 g	1. 180 W 2. 90 W	1. 5 mins 2. 15 – 20 mins
Cakes, moist, e.g. fruit flan, cheesecake ⁵	750 g	1. 180 W 2. 90 W	1. 7 mins 2. 15 – 20 mins

¹ Turn the food several times.

² Separate any defrosted parts when turning.

³ Carefully stir the food occasionally.

⁴ Remove all packaging.

⁵ Only defrost cakes without icing, whipped cream, gelatine or custard.

⁶ Separate the pieces of cake.

Tips on defrosting, heating and cooking with the microwave next time

Follow these tips for good results when defrosting, heating and cooking with the microwave.

Issue	Tip
Your food is too dry.	<ul style="list-style-type: none"> ■ Reduce the cooking time or select a lower microwave power setting. ■ Cover the food and add more liquid.

Issue	Tip
The time has elapsed but the food is not defrosted, hot or cooked.	Increase the cooking time. Large quantities and food which is piled high require longer times.

Issue	Tip
The time has elapsed but your food is not yet done on the inside, but is already overdone on the outside.	<ul style="list-style-type: none"> ■ Stir occasionally. ■ Reduce the microwave power setting and increase the cooking time.
After defrosting, the poultry or meat is defrosted on the outside but not defrosted in the middle.	<ul style="list-style-type: none"> ■ Reduce the microwave power setting. ■ Turn large pieces of frozen food several times.

22.3 Heating

With your appliance you can heat food.

Heating up or cooking frozen food with the microwave

Observe the recommended settings for using the microwave to heat food.

Note:

Cooking tips

- Use microwave-safe cookware with a lid. You can also use a plate or a microwave cover to cover the dish. Take ready meals out of the packaging.
- Distribute the food flat in the cookware. Food which lies flat cooks more quickly than food which is piled high.
- Place the cookware on the bottom of the cooking compartment.
- The food transfers heat to the cookware. The cookware can become very hot. Use oven gloves.
- Turn or stir the food 2 to 3 times during this time.
- After heating, leave the food to rest for 2 to 5 minutes.
- The food will retain most of its natural flavor. Use salt and seasonings sparingly.

Food	Weight	Microwave output setting	Duration
Set menu, plated meal, ready meal with 2–3 components	300 – 400 g	600 W	8 – 13 mins
Soup	400 g	600 W	8 – 12 mins
Stews	500 g	600 W	10 – 15 mins
Slices or pieces of meat in sauce, e.g. goulash	500 g	600 W	10 – 15 mins
Fish, e.g. fillet steaks	400 g	600 W	10 – 15 mins
Bakes, e.g. lasagne, cannelloni	450 g	600 W	10 – 15 mins
Side dishes, e.g. rice, pasta ¹	250 g	600 W	3 – 7 mins
Side dishes, e.g. rice, pasta ¹	500 g	600 W	8 – 12 mins
Vegetables, e.g. peas, broccoli, carrots ¹	300 g	600 W	7 – 11 mins
Vegetables, e.g. peas, broccoli, carrots ¹	600 g	600 W	14 – 17 mins
Creamed spinach ²	450 g	600 W	10 – 15 mins

¹ Add a little liquid to the food.

² Cook the food without any additional water.

Heating food in the microwave

Observe the recommended settings for using the microwave to heat food.

⚠ WARNING – Risk of scalding!

There is a possibility of delayed boiling when a liquid is heated. This means that the liquid reaches the boiling temperature without the usual steam bubbles rising to the surface. Exercise caution even when only gently shaking the container. The hot liquid may suddenly boil over and splatter.

- ▶ Always place a spoon in the container when heating liquids. This prevents delayed boiling.

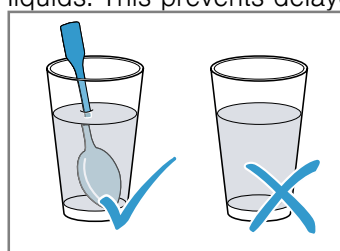

ATTENTION!

Metal touching the wall of the cooking compartment will cause sparks, which may damage the appliance or the inner door pane.

- ▶ Metal (e.g. a spoon in a glass) must be kept at least 2 cm from the cooking compartment walls and the inside of the door.

Note:

Cooking tips

- Use microwave-safe cookware with a lid. You can also use a plate or a microwave cover to cover the dish. Take ready meals out of the packaging.
- Place the cookware on the bottom of the cooking compartment.
- Turn or stir the food 2 to 3 times during this time.
- After heating, leave the food to rest for 2 to 5 minutes.
- The food transfers heat to the cookware. The cookware can become very hot. Use oven gloves.

Food	Weight	Microwave output setting	Duration
Set menu, plated meal, ready meal with 2–3 components		600 W	5 – 8 mins
Drinks ^{1, 2, 3}	125 ml	900 W	0:30 – 1 min.
Drinks ^{1, 2, 3}	200 ml	900 W	1 – 2 mins
Drinks ^{1, 2, 3}	500 ml	900 W	3 – 4 mins
Baby food, e.g. baby bottles ^{4, 5, 6}	50 ml	360 W	Approx. 0:30 mins
Baby food, e.g. baby bottles ^{4, 5, 6}	100 ml	360 W	0:30 – 1 min.
Baby food, e.g. baby bottles ^{4, 5, 6}	200 ml	360 W	1 – 2 mins
Soup, 1 cup	175 g each	600 W	1 – 2 mins
Soup, 2 cups	175 g each	600 W	2 – 3 mins
Meat in sauce	500 g	600 W	7 – 10 mins
Stew	400 g	600 W	5 – 7 mins
Stew	800 g	600 W	7 – 8 mins
Vegetables, 1 portion	150 g	600 W	2 – 3 mins
Vegetables, 2 portions	300 g	600 W	3 – 5 mins

¹ Place a spoon in the glass.

² Do not overheat alcoholic drinks.

³ Check the food occasionally.

⁴ Heat up baby food without the teat or lid.

⁵ Always shake the food well after heating.

⁶ Always check the temperature.

22.4 Cooking

With your appliance you can cook food.

Cooking with the microwave

Note:

Cooking tips

- Use microwave-safe cookware with a lid. You can also use a plate or a microwave cover to cover the dish. Take ready meals out of the packaging.
- Distribute the food flat in the cookware. Food which lies flat cooks more quickly than food which is piled high.
- Place the cookware on the bottom of the cooking compartment.
- The food transfers heat to the cookware. The cookware can become very hot. Use oven gloves.
- After heating, leave the food to rest for 2 to 5 minutes.

- The food will retain most of its natural flavor. Use salt and seasonings sparingly.

Food	Weight	Microwave output setting	Duration
Whole chicken, fresh, without giblets ¹	1200 g	600 W	25 – 30 mins
Fish fillet, fresh	400 g	600 W	7 – 12 mins
Vegetables, fresh ^{2, 3, 4}	250 g	600 W	6 – 10 mins
Vegetables, fresh ^{2, 3, 4}	500 g	600 W	10 – 15 mins
Potatoes ^{2, 3, 4}	250 g	600 W	8 – 10 mins
Potatoes ^{2, 3, 4}	500 g	600 W	12 – 15 mins
Potatoes ^{2, 3, 4}	750 g	600 W	15 – 22 mins
Rice ⁵	125 g	1. 600 W 2. 180 W	1. 4 – 6 mins 2. 12 – 15 mins
Rice ⁵	250 g	1. 600 W 2. 180 W	1. 6 – 8 mins 2. 15 – 18 mins
Desserts, e.g. blancmange (instant) ⁴	500 ml	600 W	5 – 8 mins
Fruit, compote ⁴	500 g	600 W	9 – 12 mins

¹ Turn the dish halfway through the cooking time.

² Cut into pieces of equal size.

³ Add a little water to the food.

⁴ Carefully stir the food occasionally.

⁵ Add double the amount of liquid.

Blancmange made from blancmange powder

WARNING – Risk of burns!

Heated food gives off heat. The cookware may become hot.

- ▶ Always use oven gloves to remove cookware or accessories from the cooking compartment.

1. Mix together one packet of blancmange powder with sugar and a little milk in a tall microwave-suitable bowl in accordance with the package instructions so that there are no lumps.

2. Add the rest of the milk and stir again.
3. Place the bowl into the cooking compartment and close the appliance door.
4. Set the appliance according to the recommended settings.
5. Only stir for the first time after 3 minutes. Then stir again every minute until it reaches the required consistency. The cooking time depends on the temperature of the milk and the container that is used.

22.5 Grilling

ATTENTION!

Acidic food may damage the grid

- ▶ Do not place acidic food, such as fruit or food with an acidic marinade directly on the pan support.

Information for those allergic to nickel

In rare cases, small amounts of nickel may pass into the food.

Note:

Cooking tips

- The temperature and baking time depend on the consistency and amount of the mixture. This is why temperature ranges are given in the tables. Begin with the lowest temperature and, if necessary, use a higher setting the next time.

- Always grill food on the wire rack with the oven door open. Place the wire rack on the glass tray so that this catches the meat juices. Do not preheat.
- Rinse the meat under cold water and pat dry with kitchen towel. Do not add salt to the meat until after it has been grilled.
- Use grill tongs to turn the grilled items. If you pierce the meat with a fork, the juices will run out and it will become dry.
- Dark meat, e.g. beef, browns more quickly than lighter-coloured meat such as veal or pork. When grilling light-coloured meat or fish, these often only brown slightly on the surface, although they are cooked and juicy on the inside.
- Pre-toast the slices of toast for toast with toppings.

Food	Weight	Cookware	Type of heating	Grill setting	Duration
Neck steaks, approx. 2 cm thick, 3 – 4 pcs	Approx. 120 g each	Wire rack + Glass pan	www	3	1st side: Approx. 15 mins 2nd side: Approx. 10 – 15 mins

¹ Grease the wire rack with oil beforehand.

Food	Weight	Cookware	Type of heating	Grill setting	Duration
Grilling sausages, 4 – 6 pcs	Approx. 150 g each	Wire rack + Glass pan	~~~~~	3	1st side: Approx. 10 – 15 mins 2nd side: Approx. 10 – 15 mins
Fish steak, 2 – 3 pcs	Approx. 150 g each	Wire rack ¹ + Glass pan	~~~~~	3	1st side: Approx. 10 mins 2nd side: Approx. 10 – 15 mins
Fish, whole, e.g. trout, 2 – 3 pcs	Approx. 150 g each	Wire rack ¹ + Glass pan	~~~~~	3	1st side: Approx. 15 mins 2nd side: Approx. 15 – 20 mins
Bread (pre-toasting), 2 – 6 slices		Wire rack	~~~~~	3	1st side: Approx. 4 mins 2nd side: Approx. 4 mins
Toast with topping, 2 – 6 slices, pre-toasted		Wire rack + Glass pan	~~~~~	3	5 – 10 mins

¹ Grease the wire rack with oil beforehand.

22.6 Combined grill and microwave

ATTENTION!

Acidic food may damage the grid

- ▶ Do not place acidic food, such as fruit or food with an acidic marinade directly on the pan support.

Information for those allergic to nickel

In rare cases, small amounts of nickel may pass into the food.

Note:

Cooking tips

- Use the wire rack to place the cookware on.
- Use heat-resistant, microwave-safe cookware.
- Place hot glass ovenware on a dry tea towel after cooking. The glass may crack if placed on a wet or cold surface.
- The times given apply to food placed in a cold cooking compartment.

- The temperature and baking time depend on the consistency and amount of the mixture. This is why temperature ranges are given in the tables. Begin with the lowest temperature and, if necessary, use a higher setting the next time.
- For bakes and gratins, use large, flat cookware. Food takes longer to cook in narrow, deep containers, and it browns more on top.
- Leave the meat to rest for another 5 to 10 minutes before carving it. This allows the meat juices to be distributed evenly so that they do not run out when the meat is carved.
- Bakes and gratins should be left to cook in the appliance for a further 5 minutes after the appliance has been switched off.
- Always set the maximum cooking time. Check the food after the shorter time specified.

Food	Weight	Microwave output setting	Type of heating	Grill setting	Duration
Pork joint, e.g. neck part ¹	Approx. 750 g	360 W	~~~~~	1	35 – 40 mins
Meat loaf, max. 7 cm deep	Approx. 750 g	360 W	~~~~~	2	Approx. 25 mins
Chicken, halved	Approx. 1200 g	360 W	~~~~~	3	40 mins
Chicken pieces, e.g. chicken quarters ^{2, 3}	Approx. 800 g	360 W	~~~~~	2	20 – 25 mins
Duck breast ^{2, 3}	Approx. 800 g	180 W	~~~~~	3	25 – 30 mins
Pasta bake (made from pre-cooked ingredients) ⁴	Approx. 1000 g	360 W	~~~~~	1	25 – 30 mins
Potato gratin (made from raw potatoes), max. 3 cm deep	Approx. 1000 g	360 W	~~~~~	2	Approx. 35 mins
Fish, with topping, not frozen	Approx. 500 g	360 W	~~~~~	3	15 mins
Baked quark, max. 5 cm deep	Approx. 1000 g	360 W	~~~~~	1	20 – 25 mins

¹ Turn after 15 minutes.

² Place with the skin side up.

³ Do not turn the food.

⁴ Sprinkle cheese over the food.

22.7 Test dishes

These overviews have been produced for test institutes to facilitate appliance testing in accordance with EN 60350-1:2013 or IEC 60350-1:2011 and EN 60705:2012, IEC 60705:2010.

Defrosting with the microwave

Food	Microwave output setting	Duration	Information
Meat, 500 g	1. 180 W 2. 90 W	1. 8 mins 2. 7 – 10 mins	Pyrex dish, 24 cm diameter Alternative: Defrost "Minced meat" automatic programme

Cooking with the microwave

Food	Microwave output setting	Duration	Information
Custard, 1000 g	1. 600 W 2. 180 W	1. 11 – 12 mins 2. 8 – 10 mins	Pyrex dish
Sponge, 475 g	600 W	7 – 9 mins	Pyrex dish, 22 cm diameter
Meat loaf, 900 g	600 W	25 – 30 mins	Pyrex cake dish, 28 cm long

Cooking with the microwave and grill

Food	Microwave output setting/type of heating	Duration	Information
Potato gratin, 1100 g	360 W + grill setting 2	30 – 35 mins	Round Pyrex dish, 22 cm diameter
Cakes	-	-	Not recommended.
Chicken, halved, approx. 1100 g	360 W + grill setting 3	Approx. 40 – 45 mins	Wire rack, glass tray

23 Installation instructions

Observe this information when installing the appliance.



23.1 Safe installation

Follow these safety instructions when installing the appliance.

- The appliance can only be used safely if it is correctly installed according to the safety instructions. The installer is responsible for ensuring that the appliance works perfectly at its installation location.
- Check the appliance for damage after unpacking it. Do not connect the appliance if it has been damaged in transit.
- Before starting up the appliance, remove any packaging material and adhesive film from the cooking compartment and the door.
- Proceed in accordance with the installation sheets for installing accessories.
- Fitted units must be temperature-resistant up to 90 °C, and adjacent unit fronts up to 65 °C.
- Do not install the appliance behind a decorative door or the door of a kitchen unit. There is a risk of overheating.
- Cut-out work on the units should be carried out before installing the appliance. Remove any shavings. Otherwise, the correct operation of electrical components may be adversely affected.

- Only a licensed professional may connect appliances without plugs. Damage caused by incorrect connection is not covered under the warranty.

⚠ WARNING – Risk of injury!

Parts that are accessible during installation may have sharp edges and may lead to cutting injuries.

- ▶ Wear protective gloves.

⚠ WARNING – Risk of fire!

It is dangerous to use an extended power cord and non-approved adapters.

- ▶ Do not use extension cables or multiple socket strips.

23.2 Scope of delivery

After unpacking all parts, check for any damage in transit and completeness of the delivery.

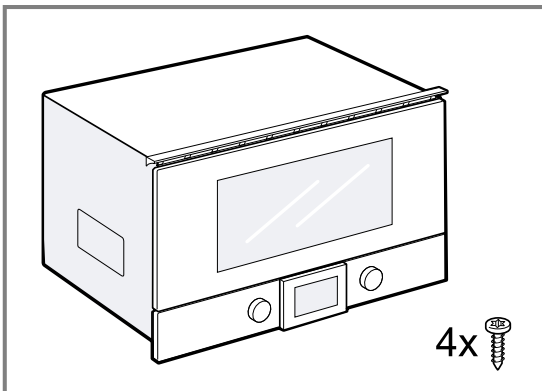

23.3 Appliance dimensions

You will find the dimensions of the appliance here

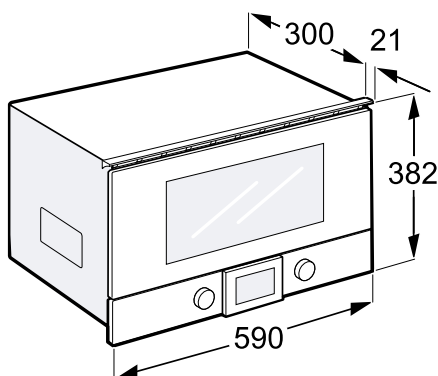

23.4 Fitted units

This appliance is only intended to be fully fitted in a kitchen. It is not intended to be used as a tabletop appliance or within a cupboard.

Ensure that the fitted cabinet behind the appliance does not have a back panel.

The minimum installation height is 850 mm.

Do not cover the ventilation slots and air intake openings.

For appliances with additional plug adapters, the minimum installation depth is 340 mm.

23.5 Electrical connection

In order to safely connect the appliance to the electrical system, follow these instructions.

- The appliance is supplied with a fitted plug and may be connected to a correctly installed earthed socket only.
- A socket must only be installed by a qualified electrician, and in accordance with the appropriate regulations.
- The fuse protection must be rated at 10 A (L or B circuit breakers). The mains voltage must correspond to the voltage specified on the rating plate.
- The appliance must only be connected using the power cable provided.
- The power cable must be plugged in at the rear of the appliance.
- Connecting cables with various plug types are available from customer service.
- If the plug is no longer accessible following installation, an all-pole isolating switch with a contact distance of at least 3 mm must be present.

23.6 Appliance combinations

When combining with other appliances, note the following.

Do not install the appliance above a steamer, a combi-steam oven or a dishwasher.

23.7 Installation in an upper cabinet

Observe the installation dimensions and the safety clearances in a tall unit.

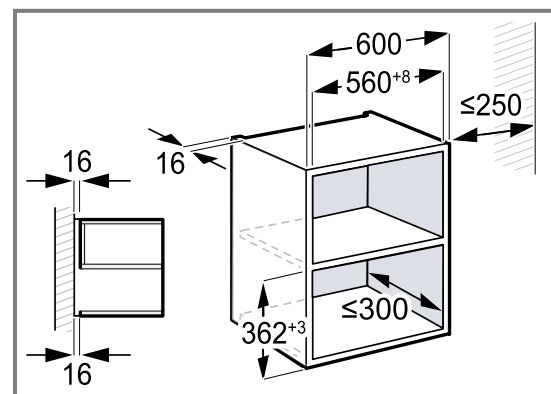

Do not fit the appliance too high up; it must be possible for accessories to be removed easily.

Remove the feet.

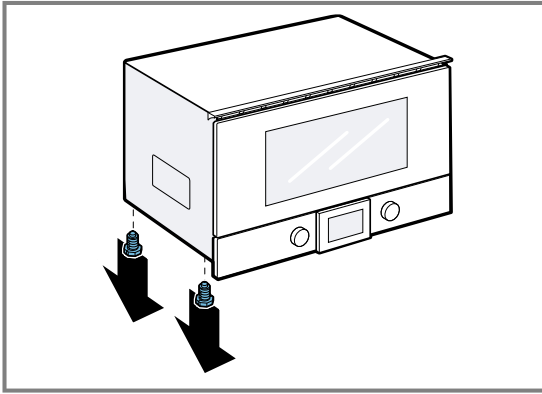

23.8 Installation in a tall unit

Observe the installation dimensions and the safety clearances in a tall unit.

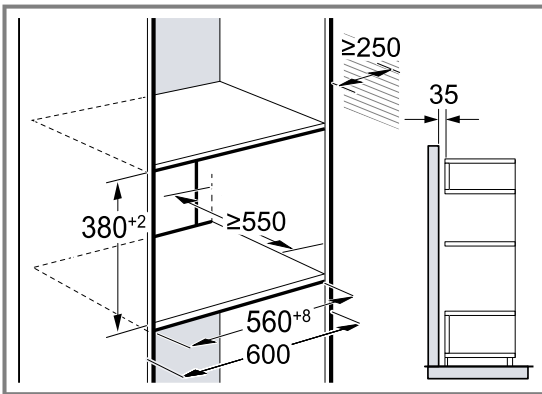

Do not fit the appliance too high up; it must be possible for accessories to be removed easily. Adjust the feet.

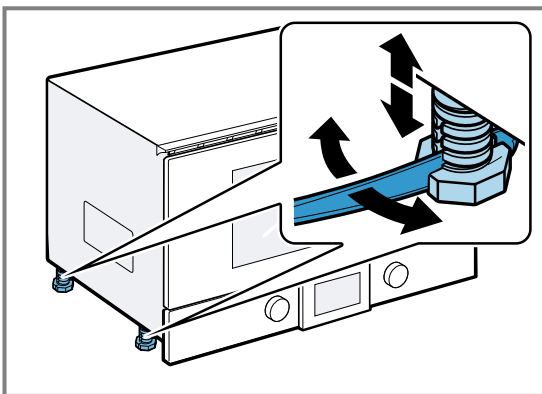

23.9 Installing the appliance

1. Push the appliance in fully.

Do not kink or trap the connection cable, or route it over sharp edges.

2. Align the appliance horizontally and centrally.
3. Use a spirit level to adjust the appliance so that it is perfectly level.
4. Open the appliance door.
5. Use the screws to screw the appliance tightly onto the unit, opposite the hinge side.

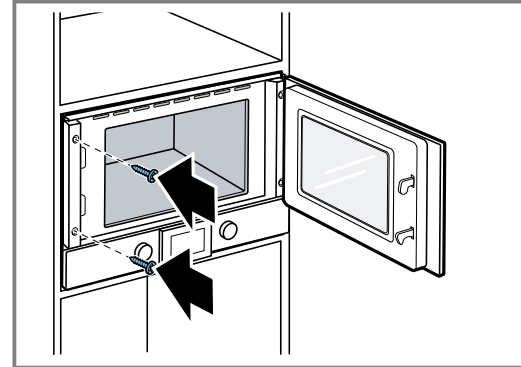

6. Pre-drill the holes on the hinge side.

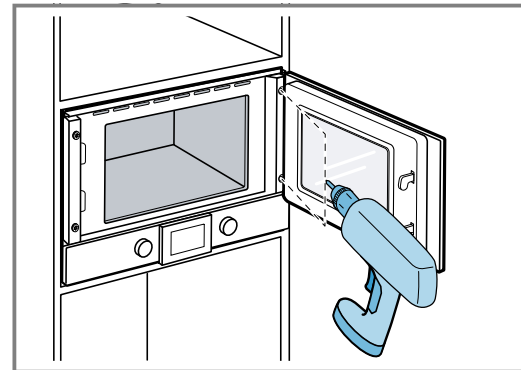

7. Screw the appliance tightly onto the unit.

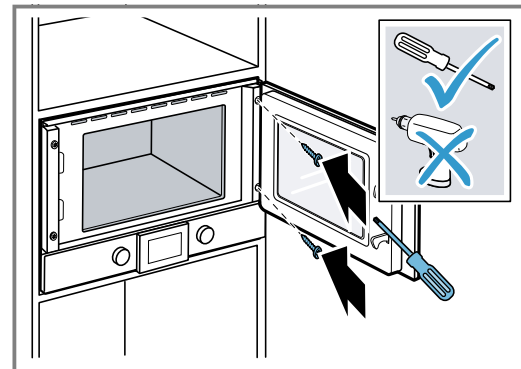

8. Remove any packaging material and adhesive film from the cooking compartment and the door.

23.10 Removing the appliance

1. Disconnect the appliance from the power supply.
2. Undo the fastening screws.
3. Lift the appliance slightly and pull it out completely.

BSH Hausgeräte GmbH
Carl-Wery-Straße 34
81739 München, GERMANY
www.gaggenau.com

GAGGENAU



9001804586 en (030302)